

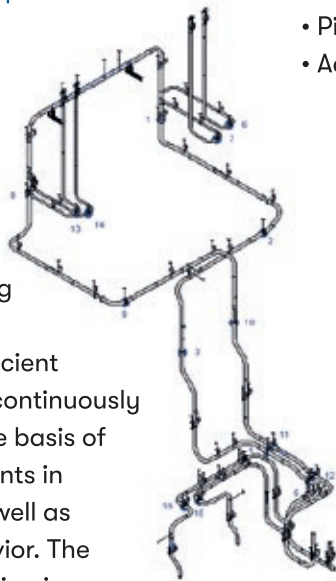

Lifetime Monitoring of Highly Stressed Pipes

The IT solution SR::SPM by STEAG Energy Services continuously monitors the lifetime of highly stressed pipes, thus creating the crucial prerequisites for an optimized condition-based maintenance in terms of an economically more efficient operation management.

Often the monitoring and maintenance of highly stressed pipes is still carried out based on experience and with high safety buffers due to time-oriented maintenance. This is time-consuming and, moreover, also extremely cost-intensive. But there is a far more efficient way. As an online system, SR::SPM continuously determines the stress of pipes on the basis of force and displacement measurements in horizontal and vertical direction as well as from the simulated expansion behavior. The required measurement instrumentation is already available in many plants.



In the intelligent calculation of the condition of highly stressed pipe sections, SR::SPM determines effective additional loads with their effects, considering the following measured variables:

- Pressure and temperature
- Pipe movements
- Actual geometries of the pipe sections

The outstanding feature:
Owing to this procedure, modes of operation that could not be predicted prior to the commissioning are included into the condition monitoring.

One of the advantages of SR::SPM is the continuous pipe simulation (reference case based on the currently measured pressures and temperatures, actual case additionally considering the force and displacement measurements). Owing to the stored pipe model, the required measurement instrumentation can be reduced to a minimum.



Strength lies in continuity – condition monitoring based on VGB Standard S-506:

- Execution of cyclic online pipe simulations considering currently measured monitoring variables
- Determination of the sectional strains from deadweight, obstructed heat expansion, friction forces, etc.
- Calculation of the stress ratios in pipe bends and other stress-critical components
- Determination of the calculatory lifetime consumption of components subject to creep stress (continuously)
- Recording, monitoring and logging of all hanger movements (continuously)

Reducing costs and optimizing processes systematically:

- Continuous monitoring of the pipe condition
- Fast detection of unplanned stresses
- Precise identification of highly stressed zones
- Systematic prevention of the lifetime reduction of highly stressed components
- Reliable detection of operating conditions that cannot be predicted in the context of the design
- Possible reduction of the inspection effort with extension of the test cycles
- Detailed proof of the specified normal operation

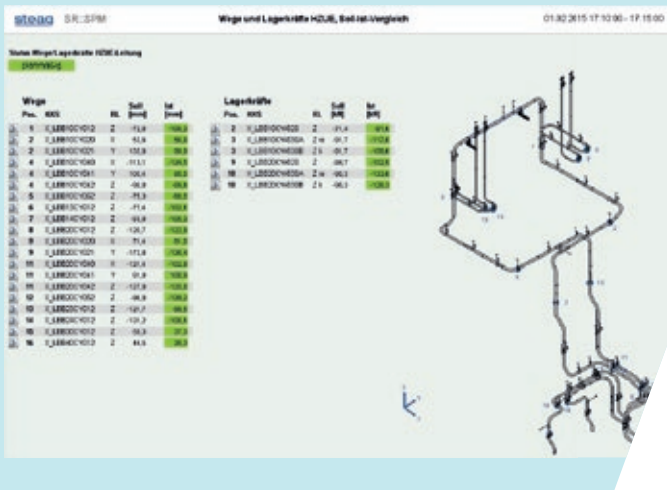

Overview displacements and forces

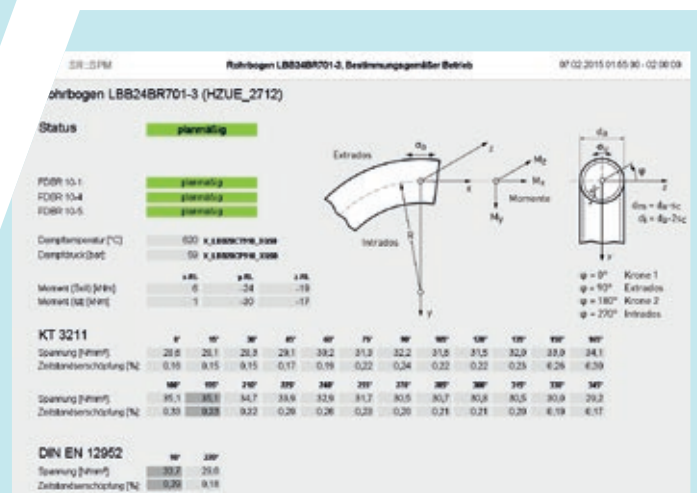

Detail view pipe bend

Contact person:
 STEAG Energy Services GmbH
 System Technologies
 Rüttenscheider Str. 1-3
 45128 Essen (Germany)

Dr. Mario Arnold
 P +49 201 801 4153
 mario.arnold@steag.com

steag-systemtechnologies.com